

Write your name here

Surname

Other names

Pearson Edexcel
International
Advanced Level

Centre Number

--	--	--	--	--

Candidate Number

--	--	--	--

Physics

Advanced Subsidiary
Unit 2: Physics at Work

Tuesday 17 October 2017 – Morning

Time: 1 hour 30 minutes

Paper Reference

WPH02/01

You must have:

Ruler

Total Marks

Instructions

- Use **black** ink or ball-point pen.
- **Fill in the boxes** at the top of this page with your name, centre number and candidate number.
- Answer **all** questions.
- Answer the questions in the spaces provided
– *there may be more space than you need.*

Information

- The total mark for this paper is 80.
- The marks for **each** question are shown in brackets
– *use this as a guide as to how much time to spend on each question.*
- Questions labelled with an **asterisk** (*) are ones where the quality of your written communication will be assessed
– *you should take particular care with your spelling, punctuation and grammar, as well as the clarity of expression, on these questions.*
- The list of data, formulae and relationships is printed at the end of this booklet.
- Candidates may use a scientific calculator.

Advice

- Read each question carefully before you start to answer it.
- Try to answer every question.
- Check your answers if you have time at the end.

Turn over ►

P50792A

©2017 Pearson Education Ltd.

1/1/1/1/1/1/



Pearson

SECTION A

Answer ALL questions.

For questions 1–10, in Section A, select one answer from A to D and put a cross in the box . If you change your mind, put a line through the box and then mark your new answer with a cross .

1 The spreading of a wave as it passes around an obstacle is called

- A diffraction.
- B polarisation.
- C reflection.
- D refraction.

(Total for Question 1 = 1 mark)

2 Unpolarised light with a power of 8 W is incident on a polarising filter.

What is the power of the light after passing through the filter?

- A 8 W
- B 4 W
- C 2 W
- D 0

(Total for Question 2 = 1 mark)

3 The current I through a wire is given by $I = nAvq$.

Which of the following is a correct statement for n ?

- A n has no unit.
- B n is equal to the number of charge carriers.
- C n is dependent on the material of the wire.
- D n is dependent on the cross-sectional area of the wire.

(Total for Question 3 = 1 mark)

DO NOT WRITE IN THIS AREA

DO NOT WRITE IN THIS AREA

DO NOT WRITE IN THIS AREA

DO NOT WRITE IN THIS AREA

DO NOT WRITE IN THIS AREA

DO NOT WRITE IN THIS AREA



4 The four diagrams represent moving wavefronts that are one wavelength apart. In each set-up, diffraction will occur as the wavefront passes through the gap.

Which set-up will produce the greatest diffraction?

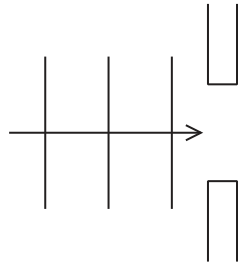

A

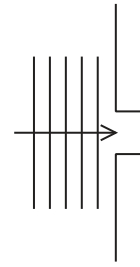

B

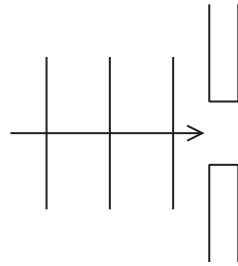

C

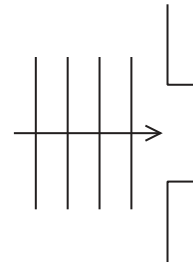

D

- A
- B
- C
- D

(Total for Question 4 = 1 mark)



- 5 An electric motor is being used to lift a load. The total input energy to the electric motor is E_{in} . Some of this energy is transferred to useful gravitational potential energy E_{grav} and the remainder to wasted energy E_{w} .

The efficiency of the motor is given by

- A $\frac{E_{\text{in}}}{E_{\text{grav}}}$
- B $\frac{E_{\text{grav}}}{E_{\text{grav}} + E_{\text{w}}}$
- C $\frac{E_{\text{in}}}{E_{\text{grav}} + E_{\text{w}}}$
- D $\frac{E_{\text{grav}} + E_{\text{w}}}{E_{\text{grav}}}$

(Total for Question 5 = 1 mark)

- 6 A wire has a resistance of $8\ \Omega$.

A second wire has twice the cross-sectional area, twice the length and twice the resistivity.

What is the resistance of the second wire?

- A $4\ \Omega$
- B $8\ \Omega$
- C $16\ \Omega$
- D $32\ \Omega$

(Total for Question 6 = 1 mark)

- 7 The energy E of a photon is given by $E = hf$.

The SI base units for h can be given as

- A $\text{kgm}^2\text{s}^{-1}$
- B kgms^{-1}
- C $\text{kgm}^2\text{s}^{-2}$
- D kgms^{-2}

(Total for Question 7 = 1 mark)



Questions 8 and 9 refer to the following information.

Pulse-echo techniques can use ultrasound. When the ultrasound pulse reaches the boundary between two materials part of it is reflected and then detected.

8 The oscilloscope screen below shows the transmitted and detected pulses.

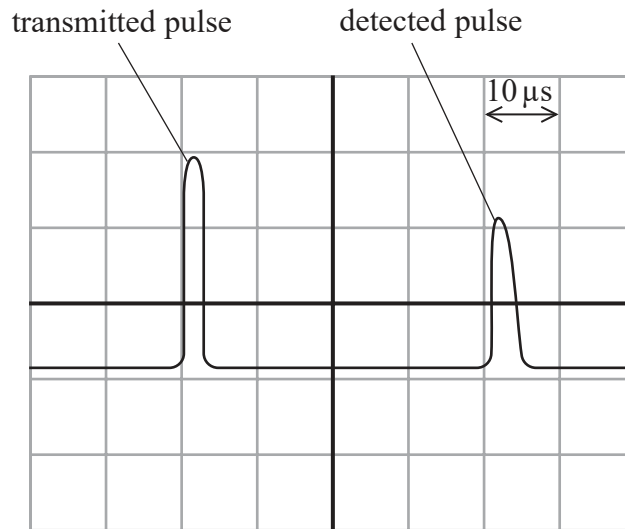

The speed of ultrasound in the first material is v .
Each division on the oscilloscope screen represents $10 \mu\text{s}$.

What is the approximate thickness of the first material?

- A $(20 \times 10^{-6}) v$
- B $(25 \times 10^{-6}) v$
- C $(40 \times 10^{-6}) v$
- D $(80 \times 10^{-6}) v$

(Total for Question 8 = 1 mark)

9 An ultrasound pulse-echo technique is used to produce an image by reflection from many boundaries.

If the transmitted pulse is too long, the image produced is of poor quality.

This could be because the

- A energy of the pulse is too high.
- B frequency of the ultrasound is too high.
- C time between consecutive transmitted pulses is too short.
- D wavelength of the ultrasound is too long.

(Total for Question 9 = 1 mark)



10 The resistance of a thermistor decreases as temperature increases. It is used in a circuit to switch on a heater as the temperature falls. The heater will switch on when the potential difference across it is greater than a certain value.

Which of the following circuits would do this?

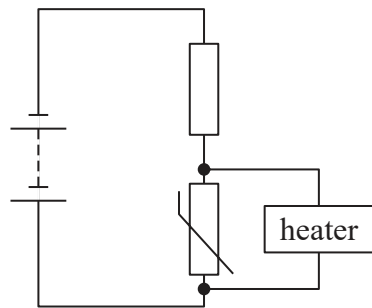

A

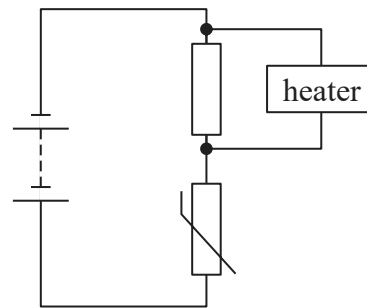

B

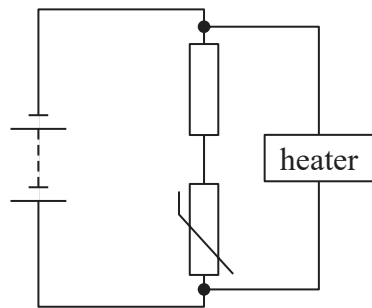

C

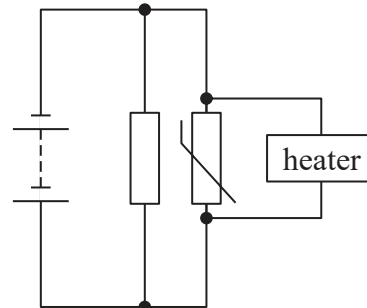

D

- A
- B
- C
- D

(Total for Question 10 = 1 mark)

TOTAL FOR SECTION A = 10 MARKS



DO NOT WRITE IN THIS AREA

DO NOT WRITE IN THIS AREA

DO NOT WRITE IN THIS AREA

DO NOT WRITE IN THIS AREA

DO NOT WRITE IN THIS AREA

DO NOT WRITE IN THIS AREA

BLANK PAGE



P 5 0 7 9 2 A 0 7 2 4

SECTION B

Answer ALL questions in the spaces provided.

- 11 A right-angled glass prism may be used in an optical device to deflect a ray of light through an angle of 90° .

The light enters the prism along a normal and is totally internally reflected, as shown.

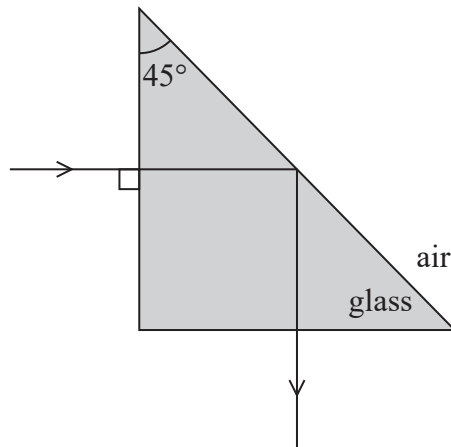

- (a) State the necessary conditions for light to be totally internally reflected at the boundary between two materials.

(2)

.....

.....

.....

.....

DO NOT WRITE IN THIS AREA

DO NOT WRITE IN THIS AREA

DO NOT WRITE IN THIS AREA

DO NOT WRITE IN THIS AREA

DO NOT WRITE IN THIS AREA

DO NOT WRITE IN THIS AREA



(b) A drop of water forms on the outside of the prism.

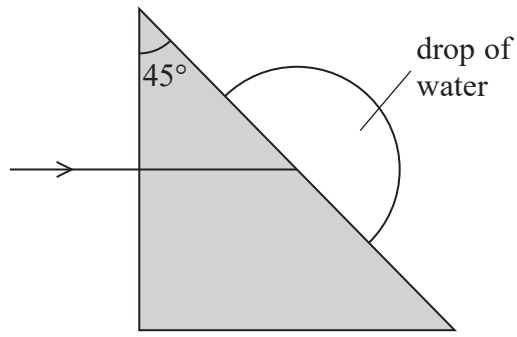

Determine whether all of the light will still be deflected through 90° by the prism.

(4)

speed of light in water = $2.25 \times 10^8 \text{ m s}^{-1}$

speed of light in glass = $2.00 \times 10^8 \text{ m s}^{-1}$

.....

.....

.....

.....

.....

.....

.....

.....

.....

.....

(Total for Question 11 = 6 marks)



12 The speed v of water waves, in shallow water, is dependent on the depth d of the water, as given by

$$v = \sqrt{gd}$$

(a) Explain how transverse waves move across water.

(2)

.....

.....

.....

.....

(b) A student investigates the speed of water waves using a tray of water. He quickly raises and lowers one end of the tray. A wave moves across the water and is reflected when it reaches the other end of the tray.

The student measures the time taken for the wave to travel four lengths of the tray. He also measures the length of the tray and the depth of water in the tray. He repeats this for different depths of water.

Describe how the student can use his results to verify $v = \sqrt{gd}$ by a graphical method.

(3)

.....

.....

.....

.....

.....

.....

.....

.....

.....

.....

.....

.....

.....

.....

.....

.....

.....

.....

.....

.....

.....

.....

.....

(Total for Question 12 = 5 marks)



DO NOT WRITE IN THIS AREA

DO NOT WRITE IN THIS AREA

DO NOT WRITE IN THIS AREA

DO NOT WRITE IN THIS AREA

DO NOT WRITE IN THIS AREA

DO NOT WRITE IN THIS AREA

13 A teacher demonstrates the Doppler effect using a rotating source of sound. He swings a buzzer on the end of a string in a wide circle. The buzzer emits sound with a constant frequency.

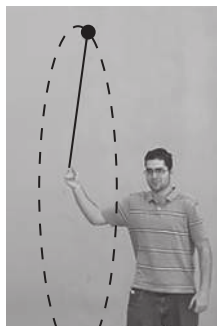

A microphone connected to a computer is placed in front of the teacher to measure the observed frequency of the sound wave. A graph of observed frequency f against time t is obtained.

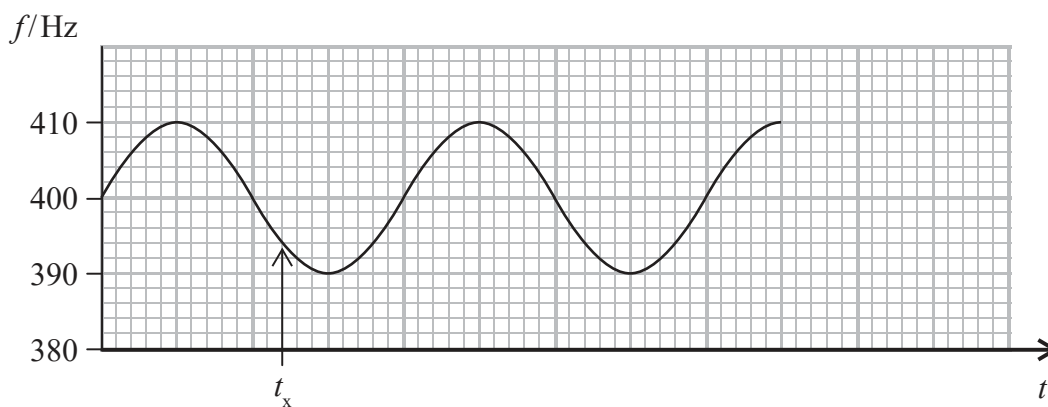

(a) (i) State the frequency of sound emitted from the source. (1)

Frequency = Hz

(ii) A student concludes “At time t_x the buzzer is moving away from the microphone”.
Justify the student’s conclusion. (1)

.....

.....

(b) The speed of rotation of the buzzer is increased.
On the same axes, sketch the graph of f against t that would now be obtained. (2)

(Total for Question 13 = 4 marks)



14 A longitudinal wave consists of a series of compressions and rarefactions.

The diagram represents the position of the particles at equilibrium and the position of the particles at a time t .

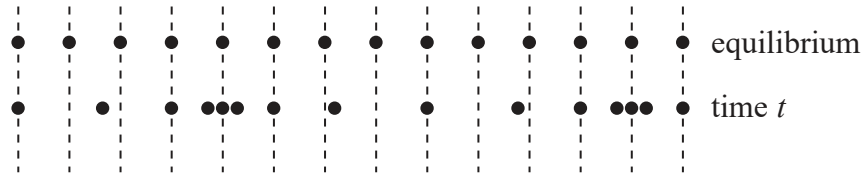

- (a) (i) Label with a C on the diagram a position where a compression occurs at time t . (1)
- (ii) Take a measurement from the diagram to determine the wavelength of the wave. (1)

Wavelength =

- (b) A longitudinal wave can also be represented as a sine graph of the displacement of the particles against distance along the wave.

On the axes below, draw a displacement-distance graph that corresponds to the longitudinal wave.

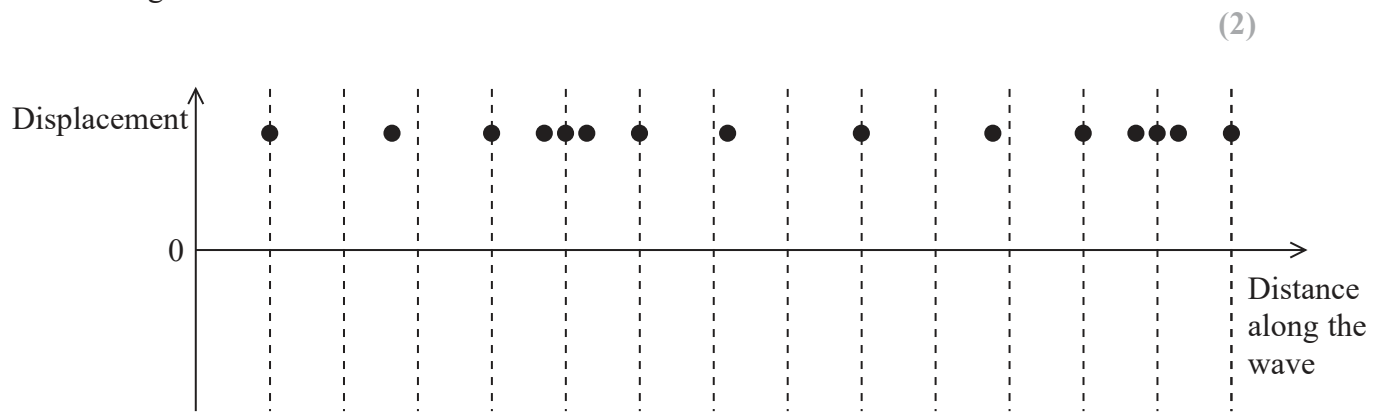

(Total for Question 14 = 4 marks)



15 In a demonstration of the photoelectric effect, electromagnetic radiation is incident on a clean metal surface.

(a) Electromagnetic radiation of frequency 1.8×10^{15} Hz is incident on a metal surface of work function 3.7 eV.

(i) Explain why photoelectrons will be released. Your answer should include a calculation. (4)

.....

.....

.....

.....

.....

.....

.....

.....

.....

.....

(ii) The electromagnetic radiation transfers energy to the metal surface at a rate of 1.8×10^{-9} J s⁻¹. Calculate the maximum number of photoelectrons that can be released each second. (2)

.....

.....

.....

.....

.....

Maximum number of photoelectrons released each second =

(b) The photoelectrons are released instantaneously. Explain how this provides evidence for the particle model of light and not the wave model. (2)

.....

.....

.....

.....

.....

(Total for Question 15 = 8 marks)



16 (a) Microwave ovens are used to cook food. Microwaves are emitted inside the oven and reflected from the sides, forming standing waves.

*(i) One problem with using a microwave oven is the formation of hot and cold spots within the food.

Explain how hot and cold spots are formed within the food.

(3)

.....

.....

.....

.....

.....

.....

(ii) The distance between two adjacent hot spots in the food is 1.4 cm.

Calculate the frequency of the microwaves.

(3)

.....

.....

.....

.....

Frequency =

(iii) Suggest how the effect of hot and cold spots is reduced by placing food on a rotating turntable.

(1)

.....

.....

DO NOT WRITE IN THIS AREA

DO NOT WRITE IN THIS AREA

DO NOT WRITE IN THIS AREA

DO NOT WRITE IN THIS AREA

DO NOT WRITE IN THIS AREA

DO NOT WRITE IN THIS AREA



(b) The interference of microwaves can be investigated in the laboratory using a microwave transmitter and receiver. Microwaves from the transmitter pass through two slits formed between metal plates, as shown.

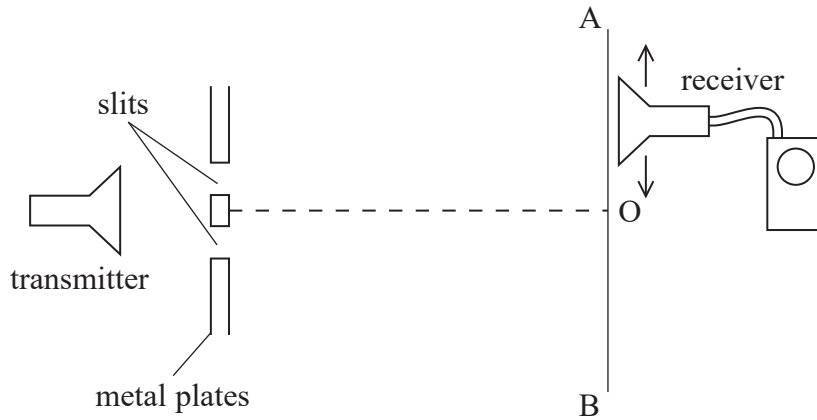

As the receiver is moved along AB, alternate points of maximum and minimum readings are observed.

* (i) Explain why O is a point of maximum reading.

(3)

.....

.....

.....

.....

.....

.....

(ii) Explain why maximum and minimum readings are observed alternately as the receiver is moved along the line AB.

(2)

.....

.....

.....

.....

(Total for Question 16 = 12 marks)



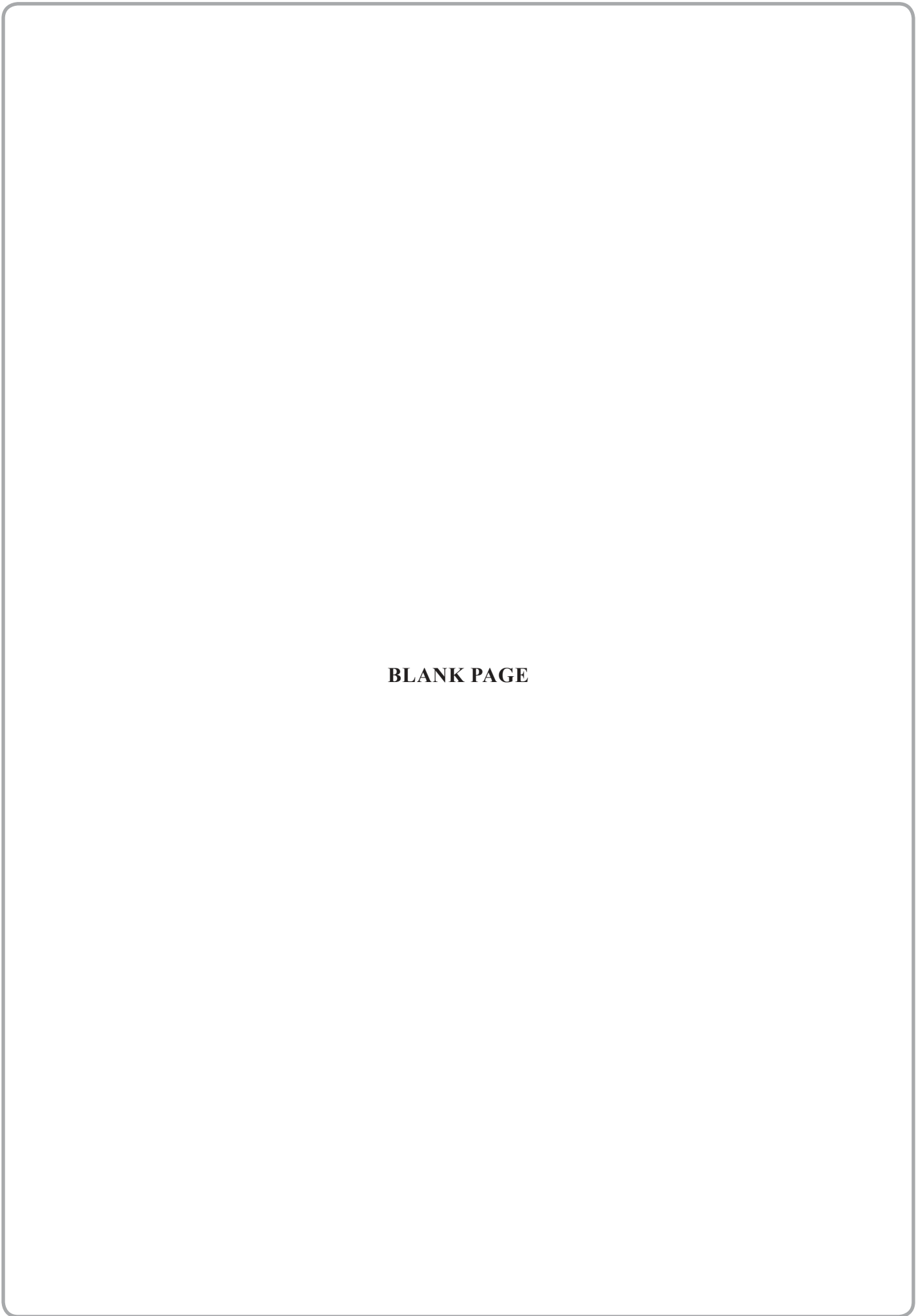

BLANK PAGE

DO NOT WRITE IN THIS AREA

DO NOT WRITE IN THIS AREA

DO NOT WRITE IN THIS AREA

DO NOT WRITE IN THIS AREA

DO NOT WRITE IN THIS AREA

DO NOT WRITE IN THIS AREA



17 The diagram shows some of the energy levels for a hydrogen atom.

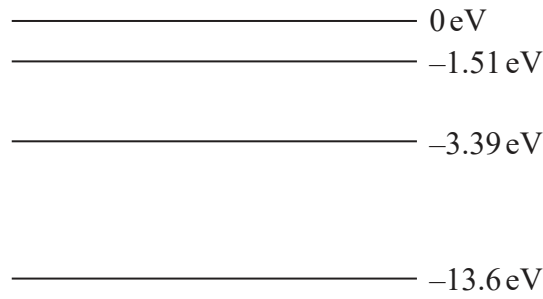

(a) State what is meant by the ground state of an atom.

(1)

(b) Under certain conditions electromagnetic radiation of wavelength 122 nm is emitted.

(i) Determine the transition which would result in the emission of electromagnetic radiation of this wavelength.

(4)

Transition from eV to eV

(ii) Identify the part of the electromagnetic spectrum to which radiation of this wavelength belongs.

(1)

(Total for Question 17 = 6 marks)



18 A car has four identical sidelights. They are connected to the battery of the car, as shown.

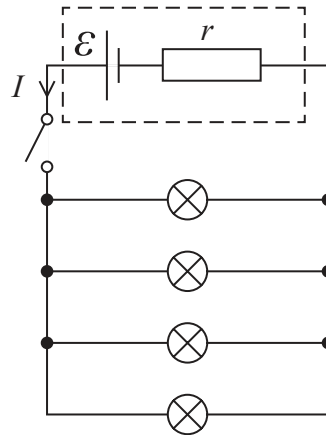

(a) Derive an expression for electromotive force \mathcal{E} in terms of current I , internal resistance r of the battery and resistance R of each bulb.

(3)

.....

.....

.....

.....

.....

(b) When the sidelights are on, the current through each bulb is 0.43 A.

Calculate the power dissipated in r .

(2)

$$r = 0.025 \Omega$$

.....

.....

.....

Power =

DO NOT WRITE IN THIS AREA

DO NOT WRITE IN THIS AREA

DO NOT WRITE IN THIS AREA

DO NOT WRITE IN THIS AREA

DO NOT WRITE IN THIS AREA

DO NOT WRITE IN THIS AREA



* (c) To start the engine a starter motor is briefly connected in parallel across the battery.
The starter motor draws a current of 120A from the battery.

Explain why the sidelights will dim as the engine is started.

(4)

.....

.....

.....

.....

.....

.....

.....

.....

(Total for Question 18 = 9 marks)

DO NOT WRITE IN THIS AREA

DO NOT WRITE IN THIS AREA

DO NOT WRITE IN THIS AREA

DO NOT WRITE IN THIS AREA

DO NOT WRITE IN THIS AREA

DO NOT WRITE IN THIS AREA



19 A student plots a graph of current I against potential difference (p.d.) V for a light emitting diode (LED).

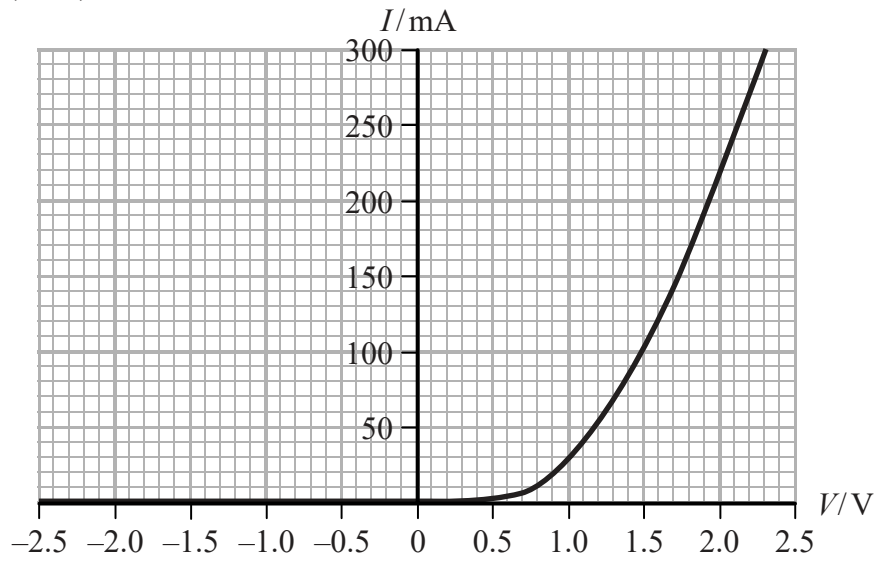

(a) State the measurements the student should make to plot the graph. Your answer should include a suitable circuit diagram.

(4)

.....

.....

.....

.....

.....

.....

.....

.....

DO NOT WRITE IN THIS AREA

DO NOT WRITE IN THIS AREA

DO NOT WRITE IN THIS AREA

DO NOT WRITE IN THIS AREA

DO NOT WRITE IN THIS AREA

DO NOT WRITE IN THIS AREA



(b) (i) Determine the resistance of the LED when $V = +2.0\text{V}$.

(2)

.....

.....

.....

Resistance of LED =

(ii) State the resistance of the LED when $V = -2.0\text{V}$.

(1)

.....

(c) The student is told that the LED will be damaged if the current is too large. To avoid damage the LED is connected in a circuit so that it is in series with a resistor of resistance R , to limit the size of the current.

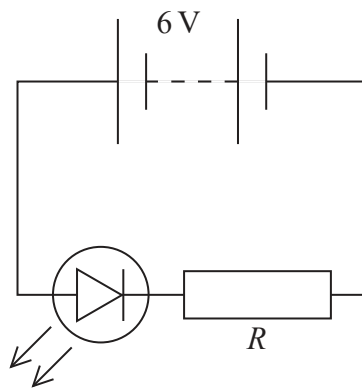

(i) With reference to the current-p.d. characteristics state why, without the resistor, the current through the LED could become too large.

(1)

.....

.....



- (ii) The intensity of the light emitted by the LED depends on the magnitude of the current through the LED. 95% of the electrons flowing through the LED cause a photon to be emitted.

The rate at which photons are emitted by the LED is $1.6 \times 10^{18} \text{ s}^{-1}$.

Use the graph to determine the value of R that will produce this rate of emission of photons.

(5)

.....

.....

.....

.....

.....

.....

.....

.....

.....

.....

.....

$R =$

- (iii) With a different value of R the p.d. across the LED is 1.8 V. The energy of the emitted photon is 77% of the work done on the electron as it moves through this p.d..

Calculate the energy of the photon.

(3)

.....

.....

.....

.....

.....

Energy =

(Total for Question 19 = 16 marks)

TOTAL FOR SECTION B = 70 MARKS
TOTAL FOR PAPER = 80 MARKS



DO NOT WRITE IN THIS AREA

DO NOT WRITE IN THIS AREA

DO NOT WRITE IN THIS AREA

DO NOT WRITE IN THIS AREA

DO NOT WRITE IN THIS AREA

DO NOT WRITE IN THIS AREA

List of data, formulae and relationships

Acceleration of free fall	$g = 9.81 \text{ m s}^{-2}$	(close to Earth's surface)
Electron charge	$e = -1.60 \times 10^{-19} \text{ C}$	
Electron mass	$m_e = 9.11 \times 10^{-31} \text{ kg}$	
Electronvolt	$1 \text{ eV} = 1.60 \times 10^{-19} \text{ J}$	
Gravitational field strength	$g = 9.81 \text{ N kg}^{-1}$	(close to Earth's surface)
Planck constant	$h = 6.63 \times 10^{-34} \text{ J s}$	
Speed of light in a vacuum	$c = 3.00 \times 10^8 \text{ m s}^{-1}$	

Unit 1

Mechanics

Kinematic equations of motion	$v = u + at$
	$s = ut + \frac{1}{2}at^2$
	$v^2 = u^2 + 2as$

Forces	$\Sigma F = ma$
	$g = F/m$
	$W = mg$

Work and energy	$\Delta W = F\Delta s$
	$E_k = \frac{1}{2}mv^2$
	$\Delta E_{\text{grav}} = mg\Delta h$

Materials

Stokes' law	$F = 6\pi\eta rv$
-------------	-------------------

Hooke's law	$F = k\Delta x$
-------------	-----------------

Density	$\rho = m/V$
---------	--------------

Pressure	$p = F/A$
----------	-----------

Young modulus	$E = \sigma/\epsilon$ where
	Stress $\sigma = F/A$
	Strain $\epsilon = \Delta x/x$

Elastic strain energy	$E_{\text{el}} = \frac{1}{2}F\Delta x$
-----------------------	--



Unit 2

Waves

Wave speed	$v = f\lambda$
Refractive index	${}_1\mu_2 = \sin i / \sin r = v_1 / v_2$

Electricity

Potential difference	$V = W/Q$
Resistance	$R = V/I$
Electrical power, energy and efficiency	$P = VI$ $P = I^2R$ $P = V^2/R$ $W = VIt$

$$\% \text{ efficiency} = \frac{\text{useful energy output}}{\text{total energy input}} \times 100$$

$$\% \text{ efficiency} = \frac{\text{useful power output}}{\text{total power input}} \times 100$$

Resistivity	$R = \rho l/A$
Current	$I = \Delta Q / \Delta t$ $I = nqvA$
Resistors in series	$R = R_1 + R_2 + R_3$
Resistors in parallel	$\frac{1}{R} = \frac{1}{R_1} + \frac{1}{R_2} + \frac{1}{R_3}$

Quantum physics

Photon model	$E = hf$
Einstein's photoelectric equation	$hf = \phi + \frac{1}{2}mv_{\text{max}}^2$

DO NOT WRITE IN THIS AREA

DO NOT WRITE IN THIS AREA

DO NOT WRITE IN THIS AREA

